



DIRECT-ACTIVATED PRESSURE REDUCING VALVE (Ductile Iron / Flange Type)



- ▶ The gate is designed for opening status, which will not influence the water supply function under unstable inlet pressure condition.
- ▶ When the outlet pressure responds directly to the pressure control chamber and adjusts the setting pressure, it responds quickly and adjusts the pressure accurately.

- ▶ Pressure Adjusting Range : 1 ~ 5 kgf/cm²
(1 kgf/cm²=14.2 psi) 3 ~ 8 kgf/cm²
- ▶ Valve Body Testing Pressure : 21 kgf/cm²
- ▶ Maximum Applied Pressure : 16 kgf/cm²
- ▶ Applied Temperature : -15 ~ 80°C
- ▶ Applied Condition : Fluid & Air

◎Special order is needed for other material and specification.

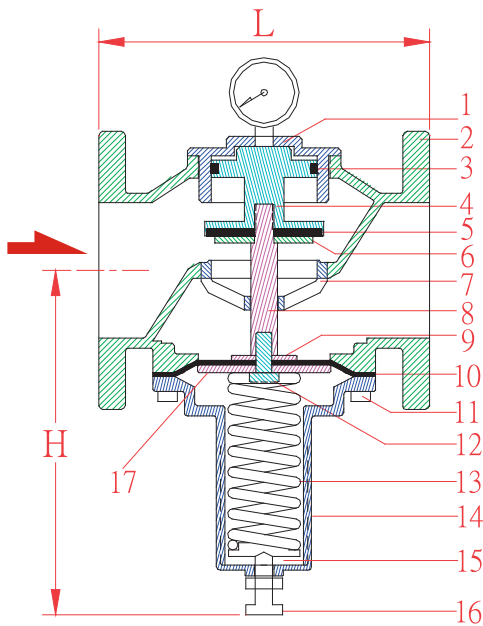

No	Part Name	Material	No	Part Name	Material
1	Upper Cover	Bronze	11	Fixed Bolt	SS 304
2	Main Body	Ductile Iron	12	Fixed Bolt	SS 304
3	U-ring	NBR	13	Spring	Spring Steel
4	Piston	Bronze	14	Lower Cover	Ductile Iron
5	Sealing Spacer	NBR	15	Washer	Brass
6	Sealing Washer	Brass	16	Adjusting Stem	SS 304
7	Shaft Guiding Seat	Bronze	17	Disk	SS 304/Cast Iron
8	Center Shaft	Brass			
9	Diaphragm Washer	SS 304			
10	Diaphragm	EPDM			

Flow Chart of Direct-activated Pressure Reducing Valve

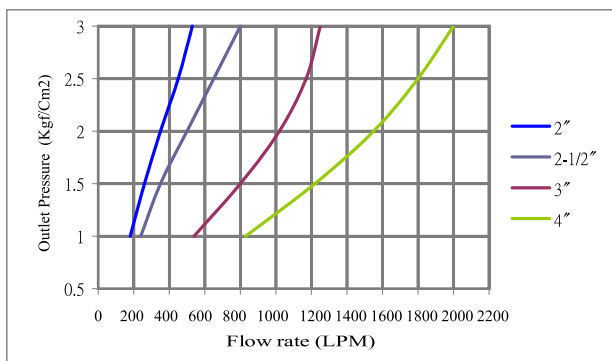

(Flange End)

Item No	Size	H(mm)	L(mm)	Weight(kg)	CV
RDF-50-F	2"	150	190	12	17.2
RDF-65-F	2.5"	165	210	17	27.5
RDF-80-F	3"	200	225	19	42.1
RDF-100-F	4"	220	250	24	66.7